

CALM Chestnut Storage Technology (formerly SOAP)

Stephen Morris

Sydney Postharvest Laboratory

Phone : 02 9490 8443 Mobile : 0410603170 Email : scmorris@postharvest.com.au

Summary

- Developed over the last 3 years by Sydney Postharvest Laboratory with Chestnut Growers of Australia (CGA) and Horticulture Australia (HAL). The final design has been finalised and is now protected by a patent.
- The basic principle is storage under high carbon dioxide with adequate oxygen levels maintained.
- Enables excellent long term control of rots in chestnuts without use of chemicals for periods of up to 12 months. Cost of running each unit (which can store up to 1.5 tonnes) is about A\$220/year.

Background

This technology was developed out of very promising controlled atmosphere (CA) work that was done supplementary to the original HAL chestnut postharvest project. It has involved lots of work on the best oxygen/carbon dioxide levels, testing different components for reliability and suitability and developing the best sealing systems.

First Model



Stick on controller, oxygen sensor in controller, cable tie bag

Second Model

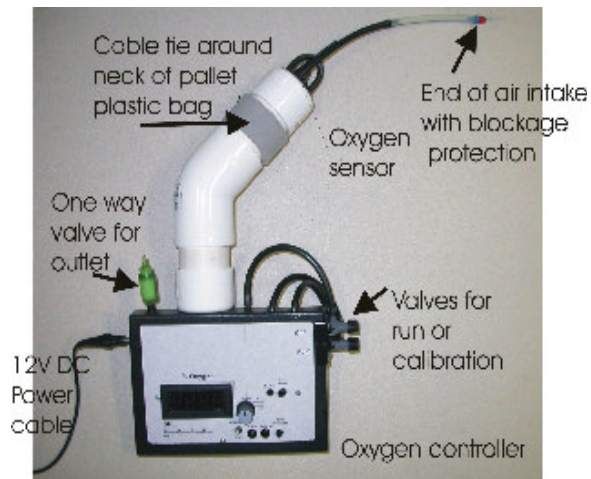

Sealing by cable tie around soft strip, sensor within bag

Third Model



Interface plate, pressure fit interchangeable connectors, sensor in bag, bag in bin

Fourth Model

Same as above but bag outside the bin or bins, need to set on solid base and seal bag at bottom and top.

Current Model

Figure 1

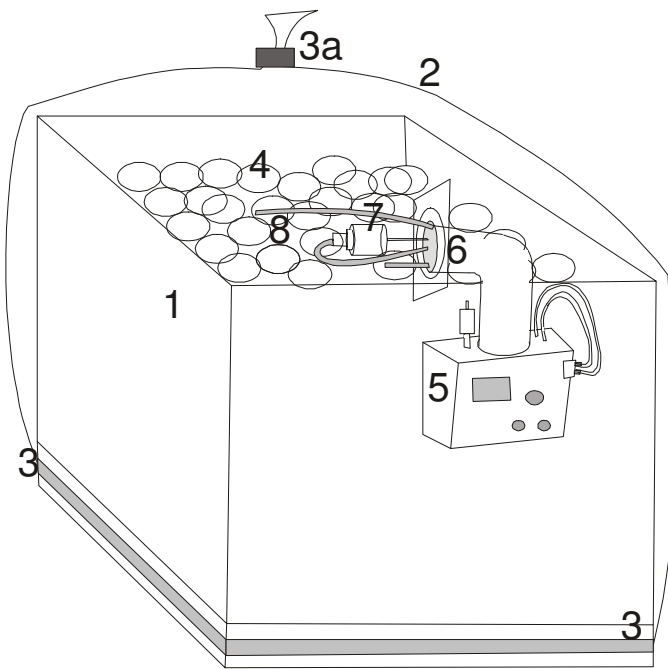
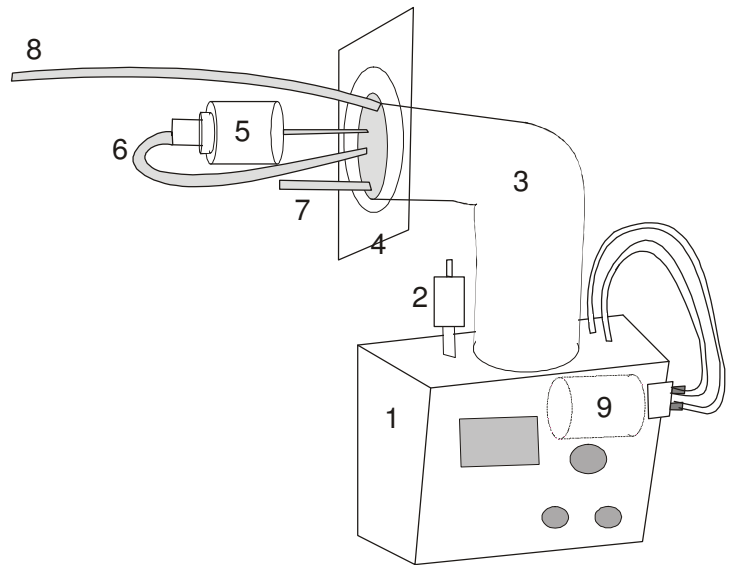
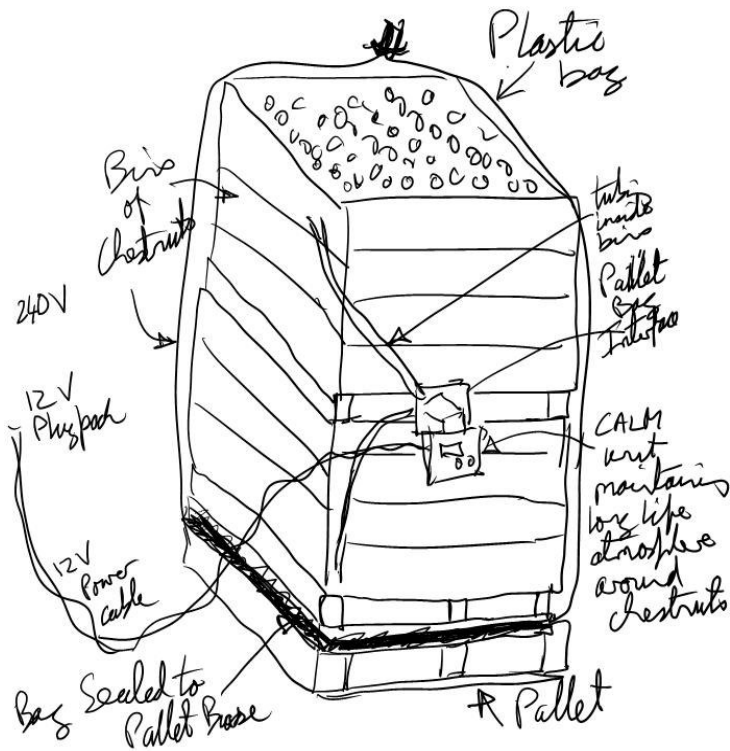
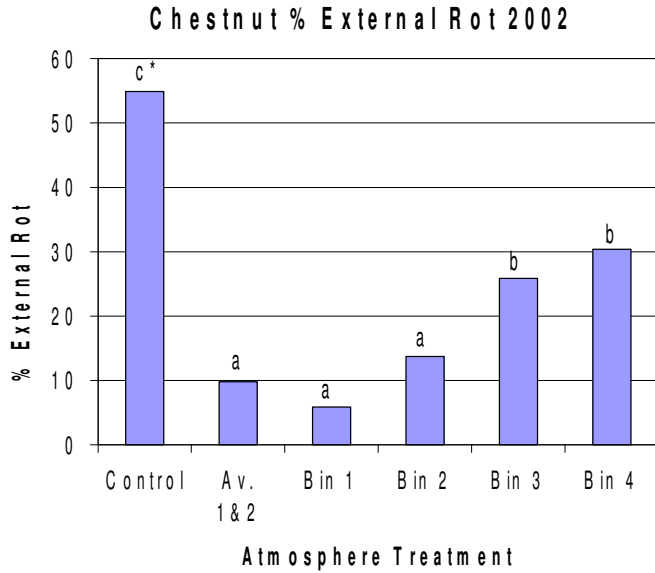

Figure 2





Benefits of Technology



* Means followed by different levels are significantly different at $k=100$ level

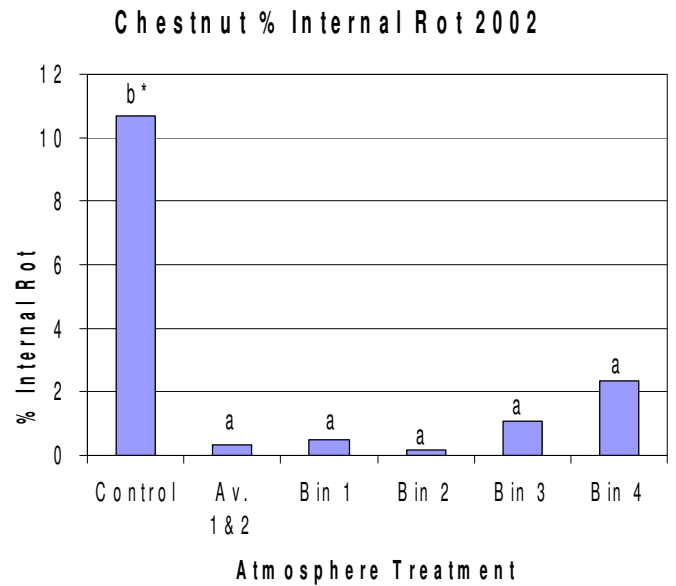

* Means followed by different levels are significantly different at $k=100$ level

Chestnut % External Rot 2004

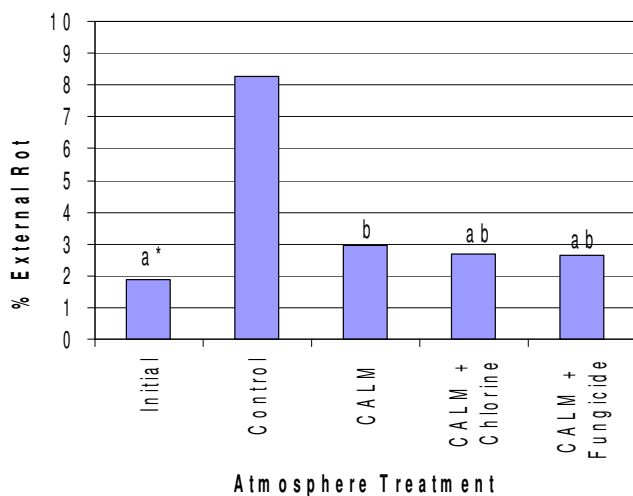

* Means followed by different levels are significantly different at $k=100$ level

Details of Current Model

Each unit can be used to store 1 to 4 bins (400 to 1600 kg) of chestnuts.

The bins of chestnuts are placed on a pallet base which seals the bottom of the bins, a plastic sleeve is placed over the bins and sealed at the pallet base and tied at the top. A pallet bag interface is then attached to the plastic bag at the top of the second bin, the CALM unit seals to the pallet bag interface, with air oxygen sensor and tubing going through the interface to provide just enough fresh air to the chestnuts to maintain the ideal storage atmosphere. The CALM unit is powered by 12V DC, so that only safe, low power cables are used within the cool rooms.

The CALM unit should last 6-9 years, as should the pallet base. The oxygen sensor needs replacing every three years, as probably would the DC power supply, the plastic bag and pump would probably last two years if handled carefully. Based on these conservative estimates the cost of storing with this system would be about A\$160/tonne/year, to greatly reduce external and internal rots and greatly extend the storage life up to 8 to 10 months if required.

Besides this amount of about A\$160 per tonne per year, the only costs of storage are a few dollars of electricity, a short time to set up the bins and regular checks during storage to ensure the units are connected to power and working normally.

[CALM Chestnut Storage Main Page](http://www.postharvest.com.au/CALM.htm)
<http://www.postharvest.com.au/CALM.htm>